

FILTER FANS

High performance 19" rack fan tray

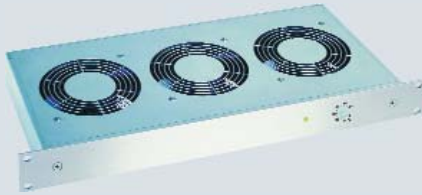

Quick Features :

- Designed for installation on 19" rack angles
- Integrated thermostat and function control light
- High air flow
- Long service life (50,000 hours at 25°C, 65%RH)
- Easy installation and connection
- Available with three, six or nine fans
- Ideal for use in Mtrx modular cabinets with 19" racks
- UL, cUL, CE

Technical Data :

Power consumption :	14.5W per fan (120V) / 15W per fan (230V)
Operating temperature :	-20°C-70°C
Static pressure :	88Pa (120V) / 74Pa (230V)
Speed :	2900 rpm (120V) / 2600 rpm (230V)
Front panel material :	Bright anodized aluminum
Frame material :	Electrogalvanized sheet metal
Connection :	IEC Norm 60320-1/C14 female power inlet Male plug provided (cable not included)
Protection class :	I (grounded)

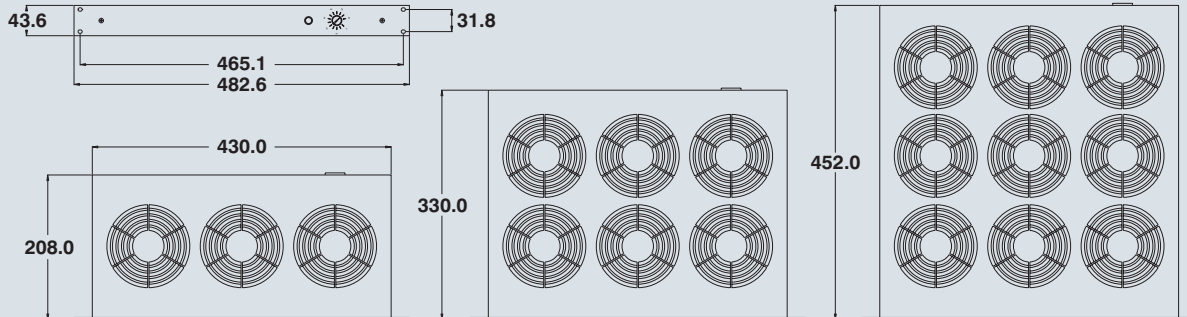

CATALOG NUMBER	VOLTAGE	NUMBER OF FANS	AIR FLOW (FREE BLOWING)	DIMENSIONS (H x W x D)	SHIPPING WEIGHT
01931.1-00	120V	3	576 m ³ /h	43.6mm x 482.6mm x 208mm	7.3
01930.1-00	230V	3	486 m ³ /h	43.6mm x 482.6mm x 208mm	7.3
01941.1-00	120V	6	1152 m ³ /h	43.6mm x 482.6mm x 330mm	12.3
01940.1-00	230V	6	972 m ³ /h	43.6mm x 482.6mm x 330mm	12.3
01951.1-00	120V	9	1726 m ³ /h	43.6mm x 482.6mm x 452mm	17.1
01950.1-00	230V	9	1456 m ³ /h	43.6mm x 482.6mm x 452mm	17.1

Data subject to change without notice.