

## Double door weatherproof enclosures

- Quick Features :**
- Seamless welding
  - Seamless poured gasket
  - 3-point Padlock handle
  - Drip shield
  - Panel included
  - 180° door opening
  - Powder coated



Visit [www.eurobex.com](http://www.eurobex.com) for details.

Call us toll free 1-800-363-2423

The 5300 ESDD large single door weatherproof enclosures are used as junction boxes or control boxes in outdoor installations or indoors where dripping water is a problem. These enclosures are designed to protect equipment against rain, sleet and snow. The 5300 ESDD are made from quality 14 GA steel, with corner seams continuously welded†. The opening has a curled lip around all sides to prevent drip-

ping water from entering the enclosure when the door is open, it also increases rigidity. A high quality robotically poured-in-place seamless gasket ensures a complete and durable weather-tight seal. The pins of the concealed hinges can be pulled out to remove the door.

The door are closed with a 3 point padlockable handle. Internal mounting holes are provided. Body stiffeners are provided.

Each enclosure comes complete with a 12 GA inner panel which is double bent for maximum rigidity and which mounts on M8 welded studs.

Enclosures and panels are finished with heat fused polyester powder, electrostatically applied on a phosphatized base. Box is ANSI/ASA 61 gray, panel is white (other colors available).

**CSA Certified**  
**NEMA 3 / IP64**

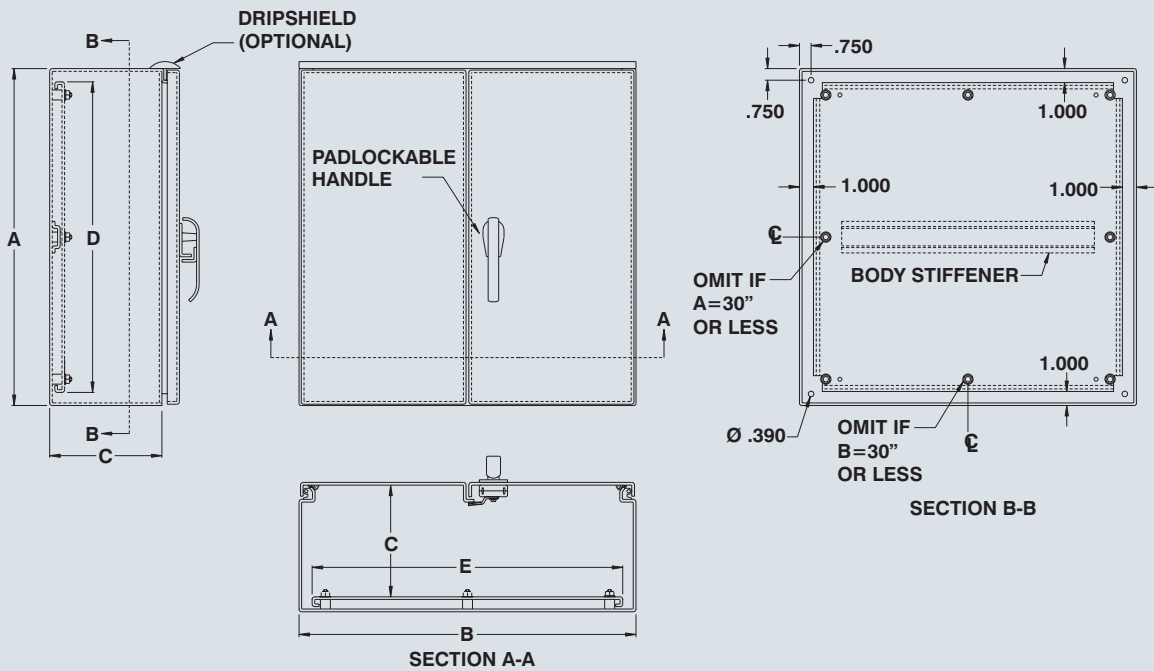

CATALOG NUMBER	DIMENSIONS					SHIP WGT LBS.
	A	B	C	D	E	
5300 ESDD303012	30	30	12	28.000	28.000	120
5300 ESDD303612	30	36	12	28.000	34.000	140
5300 ESDD304212	30	42	12	28.000	40.000	160
5300 ESDD304812	30	48	12	28.000	46.000	180
5300 ESDD363012	36	30	12	34.000	28.000	140
5300 ESDD363612	36	36	12	34.000	34.000	160
5300 ESDD364212	36	42	12	34.000	40.000	180
5300 ESDD364812	36	48	12	34.000	46.000	200
5300 ESDD303016	30	30	16	28.000	28.000	130
5300 ESDD303616	30	36	16	28.000	34.000	150
5300 ESDD304216	30	42	16	28.000	40.000	170
5300 ESDD363016	36	30	16	34.000	28.000	150
5300 ESDD363616	36	36	16	34.000	34.000	170
5300 ESDD364216	36	42	16	34.000	40.000	190

† Only enclosures with depths 12" or less are continuously welded. Shown left with optional 880 ESDD external drip shield, see p.365.

Data subject to change without notice.

## Suggested Accessories

