

## Painted stainless steel JIC enclosures

The 5412 ESSPCH are used indoors or outdoors to protect the enclosed controls from dust, dirt, oil and water splashing. The 5412 ESSPCH are made from quality 16 GA (Type 304) stainless steel, with corner seems continuously welded. The opening has a curled lip around all sides to prevent dripping water from entering the enclosure when the door is open, it also increases rigidity. A high quality robotically poured-in-place seamless gasket ensures a complete and durable water tight seal. This enclosure features

incorporated hinging, meaning that the hinge is a part of the box and part of the cover. This minimizes the amount of welding and allows the door to be easily removed by pulling out the full length mushroom head hinge pin. Very few JIC type enclosures offer this considerable advantage. **EXM's exclusive flange-mounted 1/4 turn locking system** ensures positive closing while leaving a full workable mounting surface on the door. Each enclosure comes **complete with a 14 GA inner panel** which mounts on

weld nuts. The four external wall-mounting holes are oblong to facilitate installation and the mounting feet are incorporated into the body of the enclosure. The powder coating further protects the stainless steel against the elements. Enclosures and panels are finished with heat fused polyester powder, electrostatically applied on a pretreaded base. Box is ANSI/ASA 61 gray, panel is white (other colors available).

**CSA Certified / UL Listed  
NEMA/EEMAC 4X / IP66**

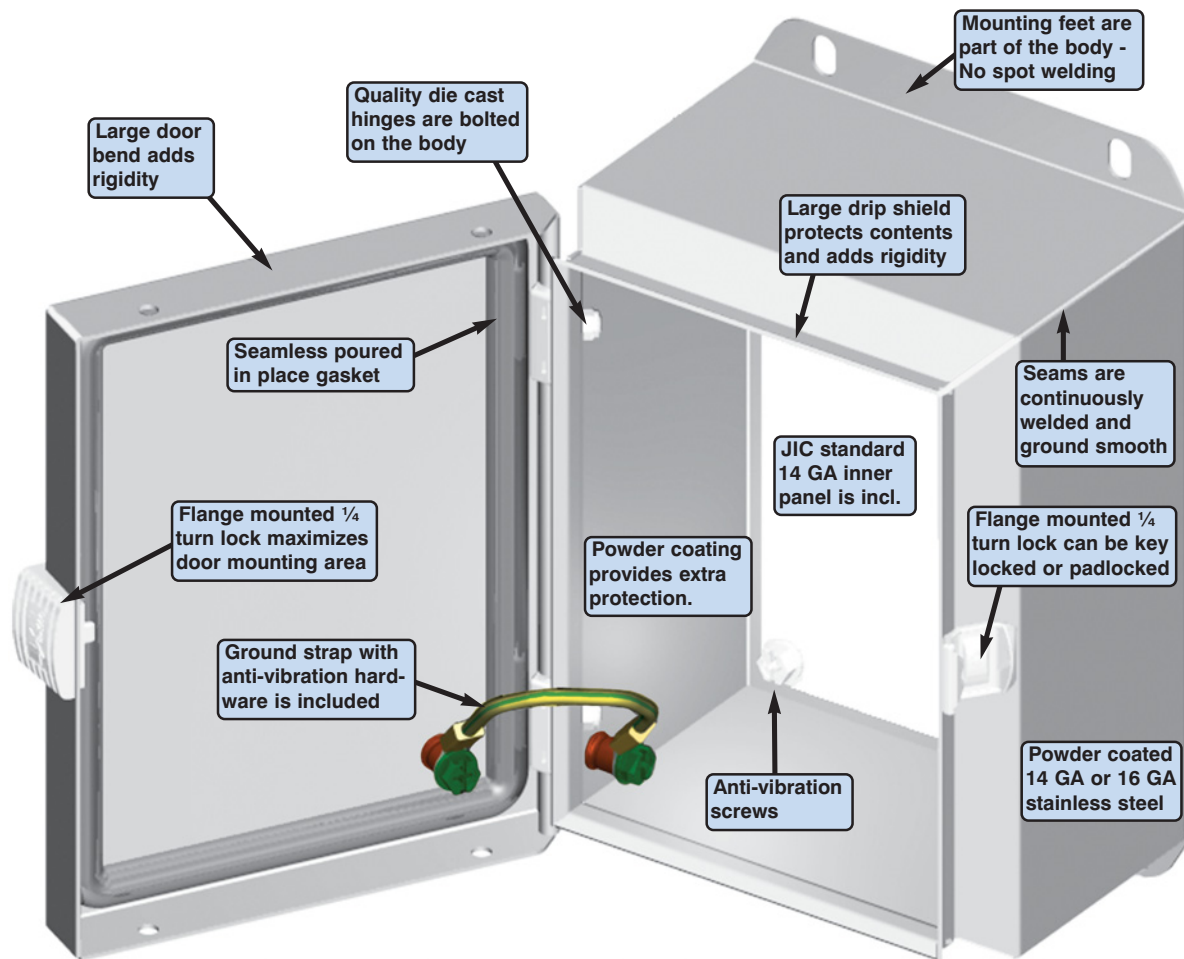

The 5412 ESSPCH -  
The advantage of coated stainless steel

Data subject to  
change without  
notice.



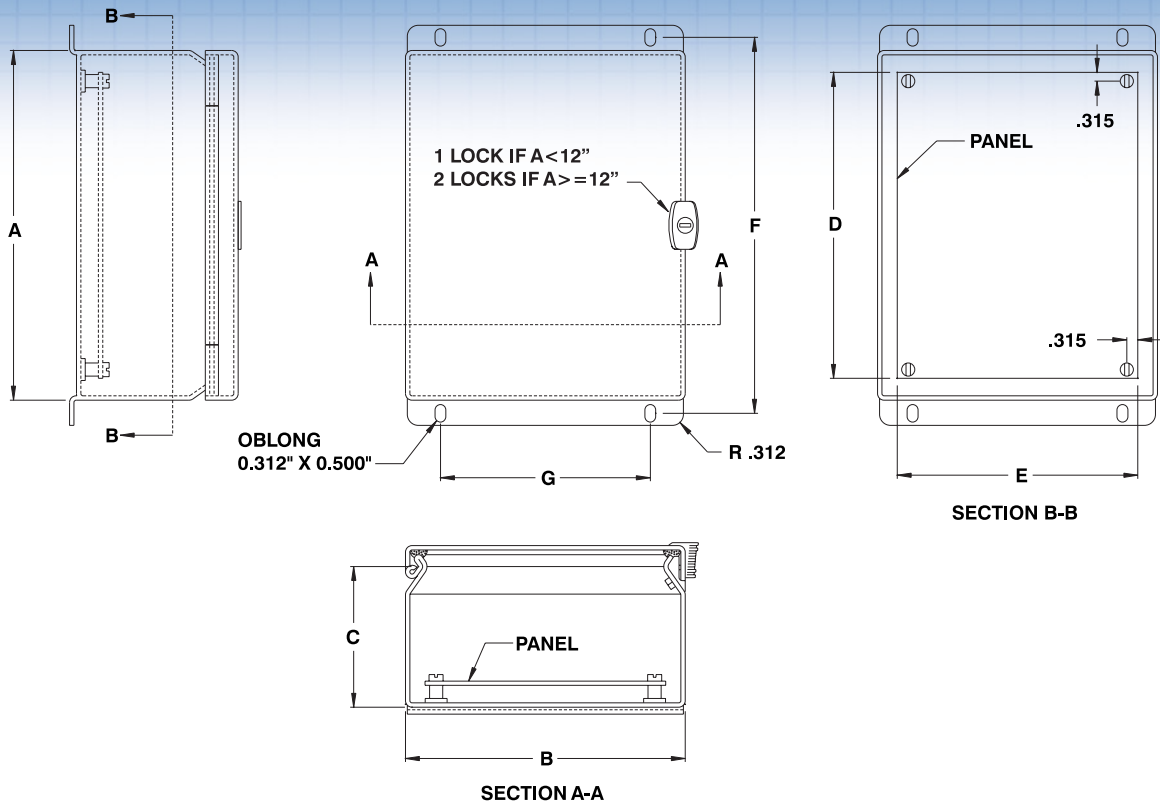

| CATALOG NUMBER    | DIMENSIONS |    |    |         |         |       |    | SHIP WGHT LBS. |
|-------------------|------------|----|----|---------|---------|-------|----|----------------|
|                   | A          | B  | C  | D       | E       | F     | G  |                |
| 5412 ESSPCH040403 | 4          | 4  | 3  | No.Pan. | No.Pan. | 4.75  | 2  | 2              |
| 5412 ESSPCH060403 | 6          | 4  | 3  | 4.88    | 2.88    | 6.75  | 2  | 3              |
| 5412 ESSPCH060404 | 6          | 4  | 4  | 4.88    | 2.88    | 6.75  | 2  | 4              |
| 5412 ESSPCH060604 | 6          | 6  | 4  | 4.88    | 4.88    | 6.75  | 4  | 5              |
| 5412 ESSPCH080604 | 8          | 6  | 4  | 6.88    | 4.88    | 8.75  | 4  | 6              |
| 5412 ESSPCH080804 | 8          | 8  | 4  | 6.88    | 6.88    | 8.75  | 6  | 8              |
| 5412 ESSPCH081004 | 8          | 10 | 4  | 6.88    | 8.88    | 8.75  | 8  | 10             |
| 5412 ESSPCH100804 | 10         | 8  | 4  | 8.88    | 6.88    | 10.75 | 6  | 10             |
| 5412 ESSPCH120604 | 12         | 6  | 4  | 10.88   | 4.88    | 12.75 | 4  | 8              |
| 5412 ESSPCH060605 | 6          | 6  | 5  | 4.88    | 4.88    | 6.75  | 4  | 6              |
| 5412 ESSPCH080605 | 8          | 6  | 5  | 6.88    | 4.88    | 8.75  | 4  | 7              |
| 5412 ESSPCH101005 | 10         | 10 | 5  | 8.88    | 8.88    | 10.75 | 8  | 14             |
| 5412 ESSPCH101205 | 10         | 12 | 5  | 8.88    | 10.88   | 10.75 | 10 | 16             |
| 5412 ESSPCH121005 | 12         | 10 | 5  | 10.88   | 8.88    | 12.75 | 8  | 16             |
| 5412 ESSPCH121205 | 12         | 12 | 5  | 10.88   | 10.88   | 12.75 | 10 | 18             |
| 5412 ESSPCH080606 | 8          | 6  | 6  | 6.88    | 4.88    | 8.75  | 4  | 7              |
| 5412 ESSPCH100806 | 10         | 8  | 6  | 8.88    | 6.88    | 10.75 | 6  | 12             |
| 5412 ESSPCH101006 | 10         | 10 | 6  | 8.88    | 8.88    | 10.75 | 8  | 14             |
| 5412 ESSPCH121206 | 12         | 12 | 6  | 10.88   | 10.88   | 12.75 | 10 | 18             |
| 5412 ESSPCH121406 | 12         | 14 | 6  | 10.88   | 12.88   | 12.75 | 12 | 19             |
| 5412 ESSPCH140806 | 14         | 8  | 6  | 12.88   | 6.88    | 14.75 | 6  | 10             |
| 5412 ESSPCH141206 | 14         | 12 | 6  | 12.88   | 10.88   | 14.75 | 10 | 19             |
| 5412 ESSPCH141606 | 14         | 16 | 6  | 12.88   | 14.88   | 14.75 | 14 | 23             |
| 5412 ESSPCH161006 | 16         | 10 | 6  | 14.88   | 8.88    | 16.75 | 8  | 19             |
| 5412 ESSPCH161206 | 16         | 12 | 6  | 14.88   | 10.88   | 16.75 | 10 | 21             |
| 5412 ESSPCH161406 | 16         | 14 | 6  | 14.88   | 12.88   | 16.75 | 12 | 23             |
| 5412 ESSPCH121008 | 12         | 10 | 8  | 10.88   | 8.88    | 12.75 | 8  | 16             |
| 5412 ESSPCH141208 | 14         | 12 | 8  | 12.88   | 10.88   | 14.75 | 10 | 20             |
| 5412 ESSPCH161208 | 16         | 12 | 8  | 14.88   | 10.88   | 16.75 | 10 | 25             |
| 5412 ESSPCH161408 | 16         | 14 | 8  | 14.88   | 12.88   | 16.75 | 12 | 26             |
| 5412 ESSPCH161410 | 16         | 14 | 10 | 14.88   | 12.88   | 16.75 | 12 | 27             |



† Add suffix '6' to the catalog number for 316 stainless steel.  
ex. 5412 ESSPCH1212066

Data subject to change without notice.